

ST100 SAFE TOUCH

PROJECT:

TYPE:

SOURCE:

NOTES:

SPECIFICATIONS



LED Chip	Cree CXA 1830 field replaceable LED board
Luminaire Output	2700 Lumens @ 700mA (26 watts) , Delivered from Luminaire with unobstructed beam.
Lumens Per Watt	100 Lumens minimum @ 26 watts, Delivered from Luminaire with unobstructed beam
CRI (3000K)	80 Standard, 90+ Optional
Colour Temperatures	2700K, 3000K, 4000K
Beam Angles	13, 20, 25, 34
Ingress Protection	IP68 *not for use in pool or ponds
Warranty	Electronics = 5 years Body Aluminium = 5 years
Standards	BS/EN 60598.2.2 cUL 1598, CSA C22.2 No. 250.0 CE

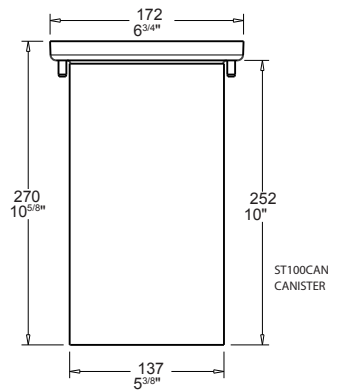
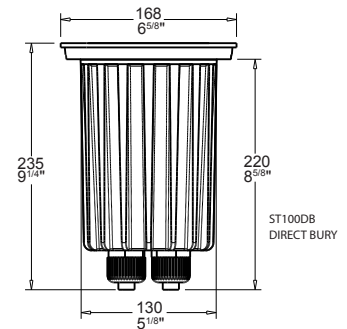

PRODUCT CONFIGURATION

Please fill in appropriate codes into boxes provided

Cat. No. ST100

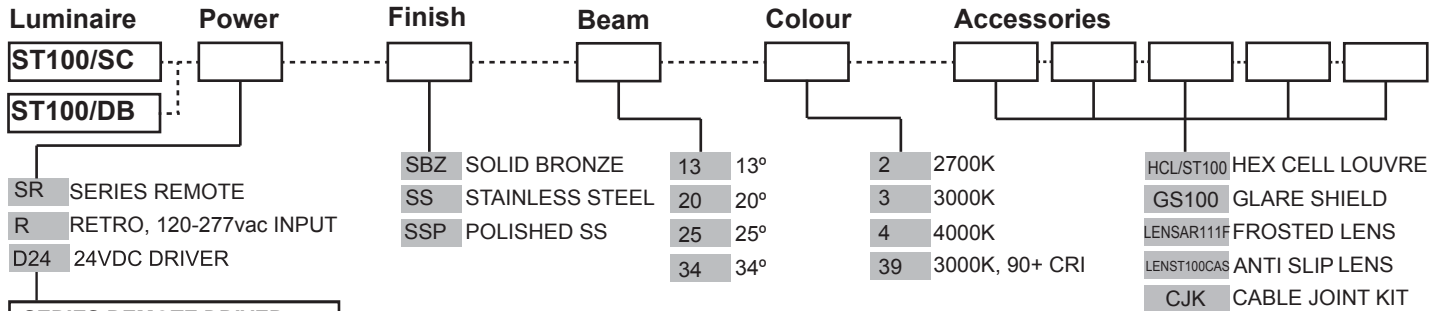

SERIES REMOTE DRIVER:
Constant current driver (included) individual fixtures require 37vdc @700mA maximum (non dimming). Dimming option available (0-10volt).

RETRO 110-277vac DRIVER:
Constant current driver (included).
Input:120, 240, 227 volts.
Output: 26 watts total 37vdc@700mA
Non dimming.
Dimming option available (0-10volt).

24VDC DRIVER:
Input: 24vdc.
Output: 36vdc @ 700mA constant current (non dimming).
Note: not for USA.

ADDITIONAL COMMENTS:

LUMINAIRE CONSTRUCTION

CNC machined or cast from one of the following metals:

Body - Cast from virgin high corrosion resistant, low copper content (0.001%) aluminium alloy. Finished with chromate substrate, Epoxy layer and a UV resistant polyester powder coat colour.
Colour - Black.

Flanges - Machined from either Solid Bronze 260mm x 6mm (10^{1/4}" x 1/4")
316 Stainless Steel 260mm x 6mm (10^{1/4}" x 1/4")

All fixings are made from 316 Stainless Steel

Step Lens:

12mm (1/2") Extra clear, low iron, shatter resistant glass. Anti Slip option available. Lifetime warranty

Gaskets:

Silicone, iron impregnated 220°C (428°F)

Cable:

Water resistant rubber

Adjustability:

The gimbal is fully adjustable, allowing 360° rotation and 0-20° elevation.

Mounting:

The ST100 is available with a 316 stainless steel mounting canister for casting into the ground or into concrete.

Maximum drive over speed 10 kp/h (6mp/h) with a maximum load rating of 2000kgs (4400lbs).

Luminaire Weight:

Stainless Steel 8kg (17lbs 10oz)
Solid Bronze 9kg (19lbs 13oz)

ACCESSORIES

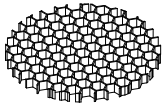

Hex Cell Louvre

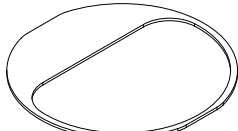

Glare Shield

BEAM ANGLES

High efficiency Reflectors. Field replaceable

IES files available for download: hunzalighting.com/downloads

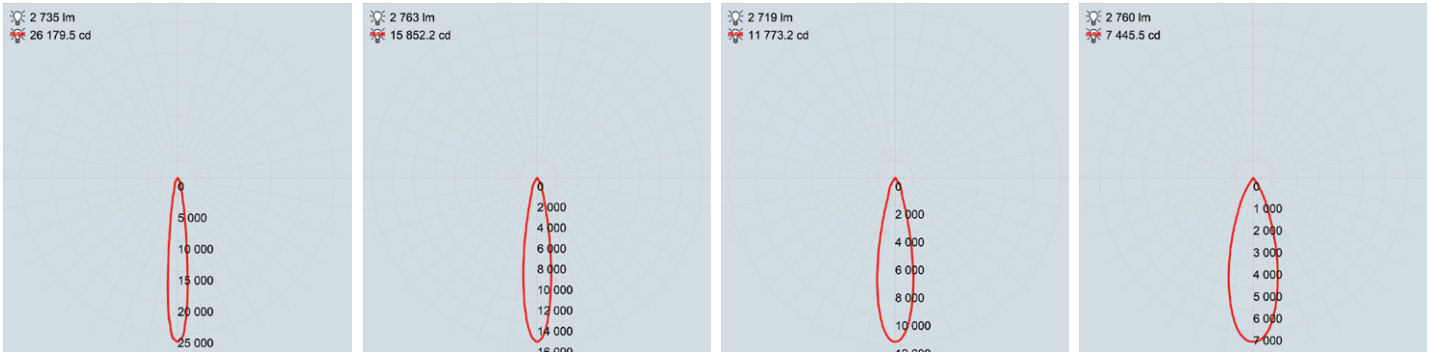

13° FWHM REFLECTOR

20° FWHM REFLECTOR

25° FWHM REFLECTOR

34° FWHM REFLECTOR

WIRING GUIDE

Available for download: hunzalighting.com/downloads

Series/remote driver

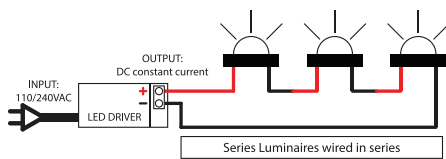

110/240v integral driver

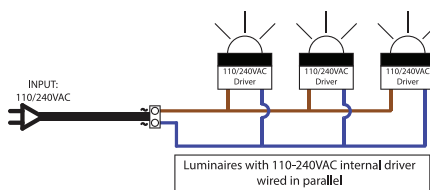

24vdc integral driver

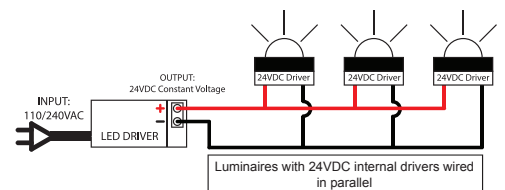

Diagrams are a guide only, wire colours and polarity may change depending on fixture and country