

Pond Lite

Cat. No. POND
Cat. No. POND/W



The Pond Lite is fully submersible and is adjustable on two planes. The luminaire is ideal for illuminating sculptures or other water features. A version with a weighted base is available, allowing the luminaire to be placed in the pond without drilling fixing holes to mount it. It is supplied with a 3 metre (10ft) submersible cable.

This luminaire is machined from a choice of 10mm solid aluminium with a UV stable powder coated finish, solid copper or 316 stainless steel with a clear, tempered, flush glass lens and high temperature silicon gaskets.

CAUTION! Do not use the copper fixtures in fish ponds!

Ordering Information

Luminaire Type

POND - Pond Lite
POND/W - Pond Lite Weighted Base

Material/Finish

BK - Black
BZ - Bronze
CT - Cotren
DG - Dark Grey
OG - Olive Green
STAR - Silver Star
WB - White Birch
WH - White
COP - Copper
SS - Stainless Steel

Accessories

CJK150 - Cable Joint Kit
GG - Glare Guard
HCL - Hex Cell Louvre
LENSSTEPF - Frosted Lens

Ordering example: POND BK - Pond Lite in Black
POND/W SS - Pond Lite Weighted Base in Stainless Steel
LENSSTEPF - Frosted Lens
(accessories ordered separately)

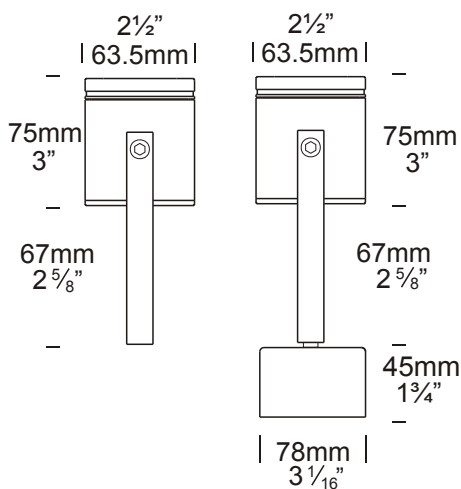

Weighted Base

HUNZA™ PURE OUTDOOR LIGHTING

HUNZA FACTORY
130 Felton Mathew Ave
Glen Innes
Auckland 1072
New Zealand

Ph: 64-9-528 9471
Fax: 64-9-528 9361
hunza@hunza.co.nz
www.hunzalighting.com

INTERNATIONAL CONTACTS:
<http://www.hunzalighting.com/contact.php>
Specification may change without notice.
Manufactured in New Zealand.
© 2016 Hunza Holdings Ltd.

Luminaire Construction

CNC machined from one of the following metals:

Aluminium

High corrosion resistant aluminium with chromate substrate and high UV resistant polyester powder coat. Body: 63.5mm (2½") x 10mm (3/8") tube.

End cap: solid aluminium 63.5mm (2½") rod.

"U" Bracket: 12mm (1/2") x 3mm (1/8") aluminium flat bar.

Colours:

Black, Bronze, Corten, Dark Grey, Olive Green, Silver Star, White, White Birch.

Copper

Body: 63.5mm (2½") x 10mm (3/8") tube.

End cap: solid copper 63.5mm (2½") rod.

"U" Bracket: 12mm (1/2") x 3mm (1/8") aluminium flat bar.

316 Stainless Steel

Body: 63.5mm (2½") x 10mm (3/8") tube.

End cap: solid stainless steel 63.5mm (2½") rod.

"U" Bracket: 12mm (1/2") x 3mm (1/8") aluminium flat bar.

Mounting

Via "U" bracket that is screwed to the mounting surface. If being used in a pond with a plastic liner then the weighted version should be used. No screws are required for fixing, therefore no leaks.

The luminaire may be mounted to a depth of 2 meters.

Note: Copper may not be suitable for use with fish.

Features

Lens

10mm (3/8") thick clear flush fit tempered shatter resistant glass.

Lifetime Warranty.

Gaskets

Silicone, iron impregnated 220°C (428°F).

Lamp Holder

MR16 - 350°C (662°F) ceramic multi contact lamp holder with 250°C (480°F) Teflon cables.

Cable

1.3mm (16AWG) 3 meter (9") submersible cable. Longer cable available on request.

Accessories

Cable Joint Kit (Cat. CJK150). Not approved for USA/Canada.

Glare Guard (Cat. GG).

Hex Cell Louvre (Cat. HCL).

Frosted Lens (Cat. LENSSTEPF).

Standards

EN60598, IP68, UL676, 

Luminaire Weight

Aluminium - 0.740kg (1lb 11oz)

Copper - 1.500kg (3lb 4oz)

Stainless Steel - 1.300kg (2lb 13oz)

Weighted version

Aluminium - 1.165kg (2lb 9oz)

Copper - 2.050kg (4lb 6oz)

Stainless Steel - 1.880kg (4lb 2oz)

Power Supply

Hunza Inground or Wall Mount

Transformer: not included.

USA and Canada

Ground shielded earth transformer: not included.

Lamp Options

MR16 - 20 or 35 watt lamp max.

USA and Canada

MR16 - 20 or 35 watt lamp max.

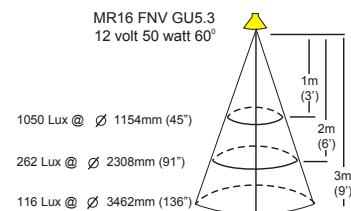
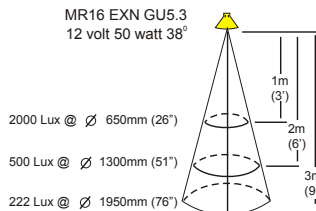
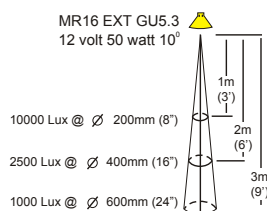
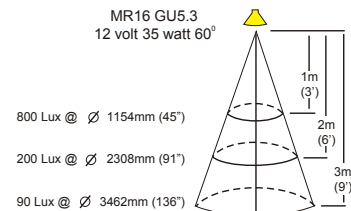
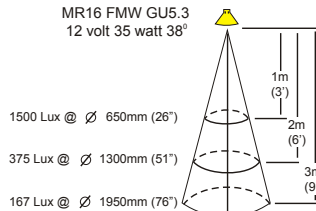
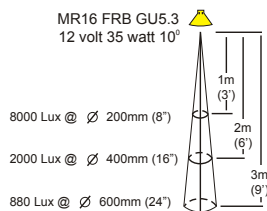
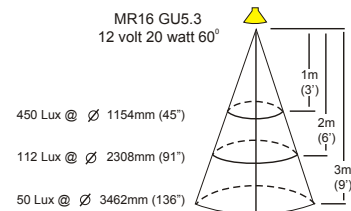
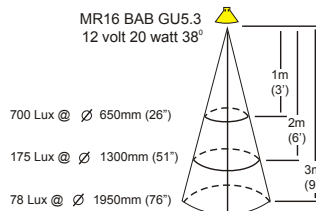
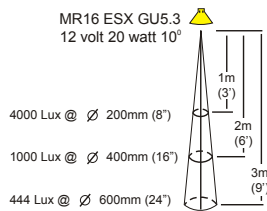

HUNZA™ PURE OUTDOOR LIGHTING

HUNZA FACTORY
130 Felton Mathew Ave
Glen Innes
Auckland 1072
New Zealand

Ph: 64-9-528 9471
Fax: 64-9-528 9361
hunza@hunza.co.nz
www.hunzalighting.com

INTERNATIONAL CONTACTS:
<http://www.hunzalighting.com/contact.php>
Specification may change without notice.
Manufactured in New Zealand.
© 2016 Hunza Holdings Ltd.